

R&S® M3SR Series4100

Software Defined Radios

HF radio family for stationary and shipborne communications





Contents

R&S®M3SR Series 4100 Software Defined Radios	4
At a glance	
Benefits and key features	
IP for easy integration	6
R&S®IPoA IP over air radio transmission	
R&S®IPoA protocol functionality	
R&S®IPoA embedded services	
IPoA with STANAG 4538	
Voice over IP, SIP and phone patch	
Audio and remote control via IP	
Phone patch	
Domain connect	
Interoperable waveforms for multinational cooperation	8
ALE-2G, R&S®GS4101S	
ALE-3G, STANAG 4538, R&S®GS4155S, R&S®GS4165S	
HF modem, R&S®GM4120S	
HF modem, R&S®GM4122S	
Secure and reliable communications	10
Secure digital voice/data (SDV), R&S®GM4121S	
R&S®SECOM-H EPM (ECCM), R&S®GS3001S	
Management of black keys for additional security	
Unrivalled radio parameters	12
Collocation capability due to excellent receiver specifications	
Selective level control for optimum transmit power (software option)	
Digitally tuned RF selection (hardware option)	
Digital IF and audio signal processing	
Suitable for a wide range of situations	13
Three power classes and suitable line of accessories	
HF broadband system	
Easy operation	14
Clear status display	
Preconfigured menus	
Radio configuration only by authorized personnel	
Low maintenance effort	15
Rugged design, suitable even for difficult environmental conditions	
Powerful built-in test (BIT)	
Excellent reliability	
Easy module exchange	

IP-based radiocommunications using R&S®Postman III	16	Software and hardware options	31
Civil and military information exchange		Description of software options	
Optimized for HF communications		Description of hardware options	
Multiline capability for simultaneous communications with multiple radio network participants		Overview of hardware and software options	
Simple and comprehensive communications applications			
Split-site system	18	Product overview	34
Split-site operation with the R&S®M3SR Series4100		R&S®EK4100A/R&S®EK4100D receiver	
Support also for secure links		R&S®XK4115A/R&S®XK4115D transceiver	
High availability and flexibility		500 W and 1000 W transceiver systems	
Lower maintenance and logistics costs		Auxiliary equipment	
		HF antenna tuning units and postselectors	
		R&S®RNMS3000 radio network management system	
		Radio test equipment	
R&S®RNMS3000 radio network management system	20		
Increased significance for a radio network management system			
R&S®RNMS3000 – the convenient way to empower the capabilities of Rohde&Schwarz radios in networks			
Highlights			
Key features			
Effective mission planning			
R&S®GP4100A fill device			
System overview	22		
Logistical structure			
R&S®M3SR Series4100 power classes			
R&S®EK4100A/R&S®EK4100D VLF-HF receiver	23		
Key features			
R&S®XK4115A/R&S®XK4115D 150 W transceiver ...	24		
R&S®IN4000A external power supply			
500 W/1000 W transceiver systems	25		
R&S®GX4100A/R&S®GX4100D receiver/exciter			
R&S®VK4150/R&S®VK4190 power amplifier			
R&S®IN4150/R&S®IN4190 standard power supply			
Antenna tuning units	27		
Key features			
R&S®FK4115M HF antenna tuning unit			
R&S®FK4150U HF antenna tuning unit			
R&S®FK4190M HF antenna tuning unit			
R&S®FK2900M 1 kW HF antenna tuning unit			
Dipoles and postselector	30		
R&S®HX002H1/R&S®HX002H2 150 W HF dipoles			
R&S®FK4190X 1 kW HF postselector			

R&S®M3SR Series4100 Software Defined Radios At a glance

Rohde & Schwarz has developed a state-of-the-art generation of communications systems designed to take HF radio to the next level. Shortwave communications are a resource that can be set up easily, offer extreme reliability and are highly valued by security authorities and organizations as well as military users all over the world.

The R&S®M3SR Series4100 HF radios are innovative, versatile software defined radios (SDR) that belong to the popular R&S®M3SR radio family. They support frequency hopping and provide interoperability with the R&S®M3TR family of tactical radios in all of the HF operating modes. Possible applications include typical navy applications on board ships and on shore, civil air traffic control, embassy radio systems and tactical applications.

Software defined radios save on logistics effort and reduce operating costs. In particular, the costs of warehousing spare parts and of maintenance are reduced tremendously. Having fewer internal hardware components also helps to significantly boost the reliability compared to conventional radios.

The R&S®M3SR Series4100 is a powerful radio platform that can be extended at any time. This helps to provide a safe, future-ready investment.

Besides the existing HF House waveforms, the R&S®M3SR Series4100 will also support future waveforms that attain a suitable level of market acceptance and lead to international standards. A software update is all that is required.

Key facts

- Frequency range: 1.5 MHz to 30 MHz (transmission), 10 kHz to 30 MHz (reception)
- Power classes of 150 W, 500 W, 1000 W and standalone receiver
- LINK 11, LINK 22, LINK Y support
- Embedded secure voice and data capability
- IP over air capability
- SIP-based remote voice operation



R&S®M3SR Series4100 Software Defined Radios Benefits and key features

IP for easy integration

- ▮ R&S®IPoA radio transmission
- ▮ R&S®IPoA protocol functionality
- ▮ R&S®IPoA embedded services
 - Alarm messages
 - Short data messages
 - GPS reporting
- ▮ IPoA with STANAG 4538
- ▮ Voice over IP, SIP and phone patch
- ▮ Audio and remote control via IP
- ▮ Phone patch
- ▮ Domain connect

Interoperable waveforms for multinational cooperation

- ▮ ALE-2G, R&S®GS4101S
- ▮ ALE-3G, STANAG 4538, R&S®GS4155S
- ▮ HF modem, R&S®GM4120S
- ▮ HF modem, R&S®GM4122S

Secure and reliable communications

- ▮ Secure digital voice (SDV), R&S®GM4121S
 - Last ditch voice
- ▮ R&S®SECOM-H EPM (ECCM), R&S®GS3001S
- ▮ Management of black keys for additional security

Unrivaled radio parameters

- ▮ Collocation capability due to excellent receiver specifications
- ▮ Selective level control for optimum transmit power (software option)
- ▮ Digitally tuned RF selection (hardware option)
- ▮ Digital IF and audio signal processing

Suitable for a wide range of situations

- ▮ Three power classes and suitable line of accessories
- ▮ HF broadband system

Easy operation

- ▮ Clear status display
- ▮ Preconfigured menus
- ▮ Radio configuration only by authorized personnel

Low maintenance effort

- ▮ Rugged design, suitable even for difficult environmental conditions
- ▮ Powerful built-in test (BIT)
- ▮ Excellent reliability
- ▮ Easy module exchange

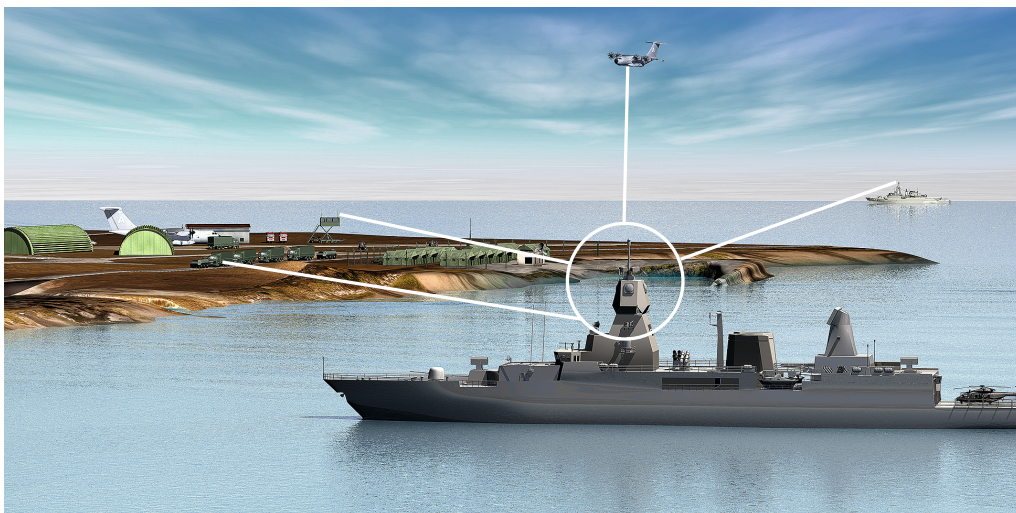

State-of-the-art secure radiocommunications.

IP for easy integration

IP is becoming generally accepted in all areas. The R&S®M3SR Series4100 offers IP support at both the air interface and the radio for receiving payload, control and audio data.

R&S®IPoA IP over air radio transmission

The R&S®IPoA embedded radio protocol provides transparent IP functionality over the air. It can be used to set up communications systems that require transparent connection of IP networks over radio links. IP-based applications – such as situational awareness or message handling systems – are able to exchange their data over such radio links.

The R&S®RNMS3000 network management system provides a wizard that creates an IPoA network structure automatically.

R&S®IPoA protocol functionality

The embedded R&S®IPoA protocol currently supports Internet protocol version 4 (IPv4). An internal address mapping function ensures that data is delivered to the correct recipient. An error detection mechanism prevents the protocol from delivering erroneous data to the connected network; additional error correction techniques (e.g. ARQ secured data) are implemented. IPoA is supported by R&S®SECOM-H and ALE-3G (STANAG 4538)

R&S®IPoA embedded services

Messages and text information can be transmitted directly from the radio HMI as well as from external sources.

Alarm messages

Alarm messages are preconfigured. They can be selected on the HMI and then transmitted with the highest priority (R&S®SECOM-H only).

Short data messages

Short data messages (SDM) can be entered directly on the HMI keyboard.

GPS reporting

GPS reporting allows the position of the own radio to be transmitted. The position of other radios can be shown on the HMI or transmitted to other applications. For example, the R&S®M3SR Series4100 radio in ALE-3G or R&S®SECOM-H can receive the position from R&S®M3TR radios in the field (blue force tracking).

IPoA with STANAG 4538

Depending on the destination IP address, an advanced, highly robust link setup with ALE-3G is used to establish a link to the appropriate radio. Once the link has been set up, the actual payload is transmitted with the xDL data link protocols from STANAG 4538 using error protection based on an integrated automatic repeat request (ARQ) procedure.

In the implementation developed by Rohde&Schwarz, the different LDL and HDL protocols are selected automatically. An intelligent choice is made based on the data size and current channel quality, due to a mechanism that ensures that the optimum waveform is always selected for maximum data throughput under a very wide range of channel conditions. Data transmission is still possible in very poor channels with a signal-to-noise ratio (SNR) as low as -7 dB.

R&S®IPoA – transparent IP data transfer over air

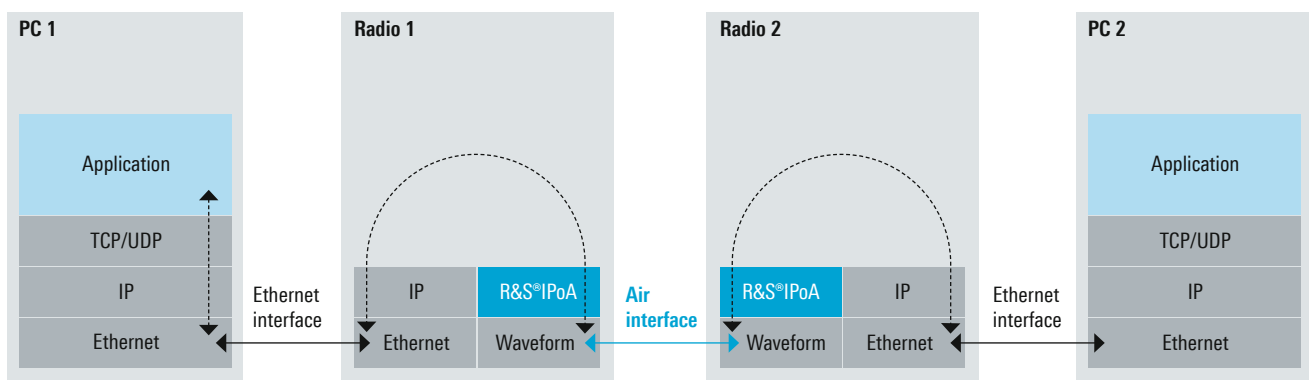

Voice over IP, SIP and phone patch

The R&S®M3SR Series4100 radio family has an IP interface as standard, which can be used for remote control, configuration and also transmission of digital voice from and to the radio. Thanks to this interface the radio can be easily integrated into systems using one cable. Although other interfaces such as audio line interface or serial RS-232 are no longer required, they are still available.

Audio and remote control via IP

Since all relevant information is transmitted via Ethernet, the operator does not have to be at the same location as the R&S®M3SR Series4100 radio, provided an IP connection is available. The audio interface complies with the EUROCAE ED-137 standard, which allows the radio to be connected to an R&S®VCS 4G IP-based voice communications system, for example.

Phone patch

The phone patch is used to integrate the R&S®M3SR Series4100 radio into an SIP phone system. With ALE-3G, participants in the radio network can also be directly reached from a standard SIP phone. In addition, the radio network participants can directly communicate with other participants via the SIP phone system. If the secure digital voice (SDV) option is used, the connection is encrypted.

Domain connect

Local VoIP domains can be interconnected. For example, VoIP networks on board ships can be connected with a shore station. It is also possible to connect remote sites to the public switched telephone network.

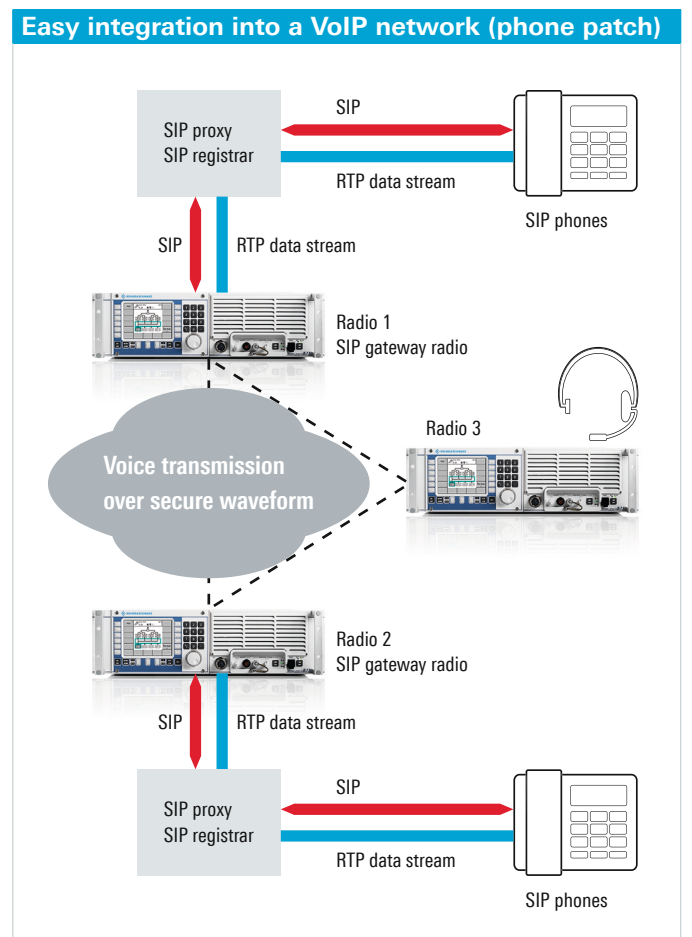
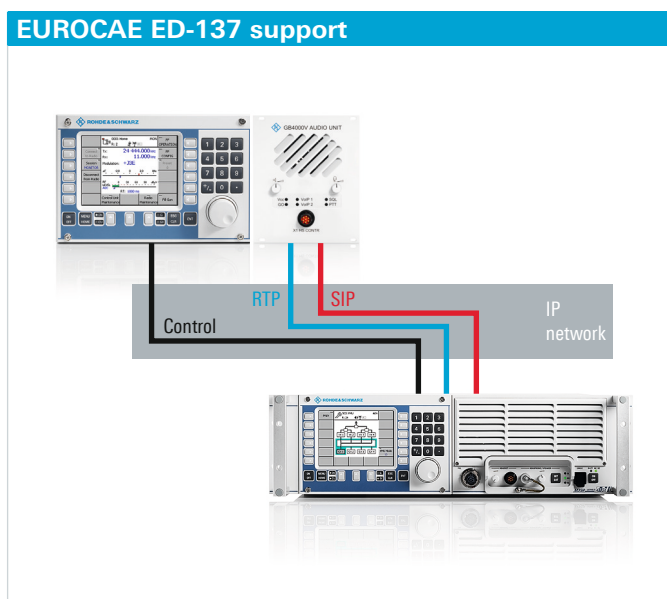

Interoperable waveforms for multinational cooperation

Interoperable waveforms are required to enable cooperation among different nations. The most important waveforms for multinational cooperation are covered by the NATO HF House. The R&S®M3SR Series4100 family supports these waveforms.

NATO has defined several standards to ensure interoperability between modern HF transceivers. The HF House is a structured overview of different HF standards ratified by the NATO countries. The R&S®M3SR Series4100 family supports most of the waveforms mentioned in the HF House. These waveforms can easily be activated by an option key.

The network layer, link layer and physical layer are embedded into the radio. This ensures high reliability and low maintenance costs since no additional hardware such as external modems is necessary. STANAG 4538 allows the radio to be directly used as a static IP router. Rohde&Schwarz products also support STANAG 5066 as an external application.

ALE-2G, R&S®GS4101S

R&S®GS4101S is the ALE software for second-generation automatic link establishment systems. This software option provides support for the FED-STD-1045/1046/1049 and MIL-STD-188-141B App. A+B standards.

ALE-3G, STANAG 4538, R&S®GS4155S, R&S®GS4165S

ALE-3G (third generation automatic link establishment) offers significant benefits compared to ALE-2G, including considerably faster and more robust link setup, improved automatic channel selection algorithms and embedded

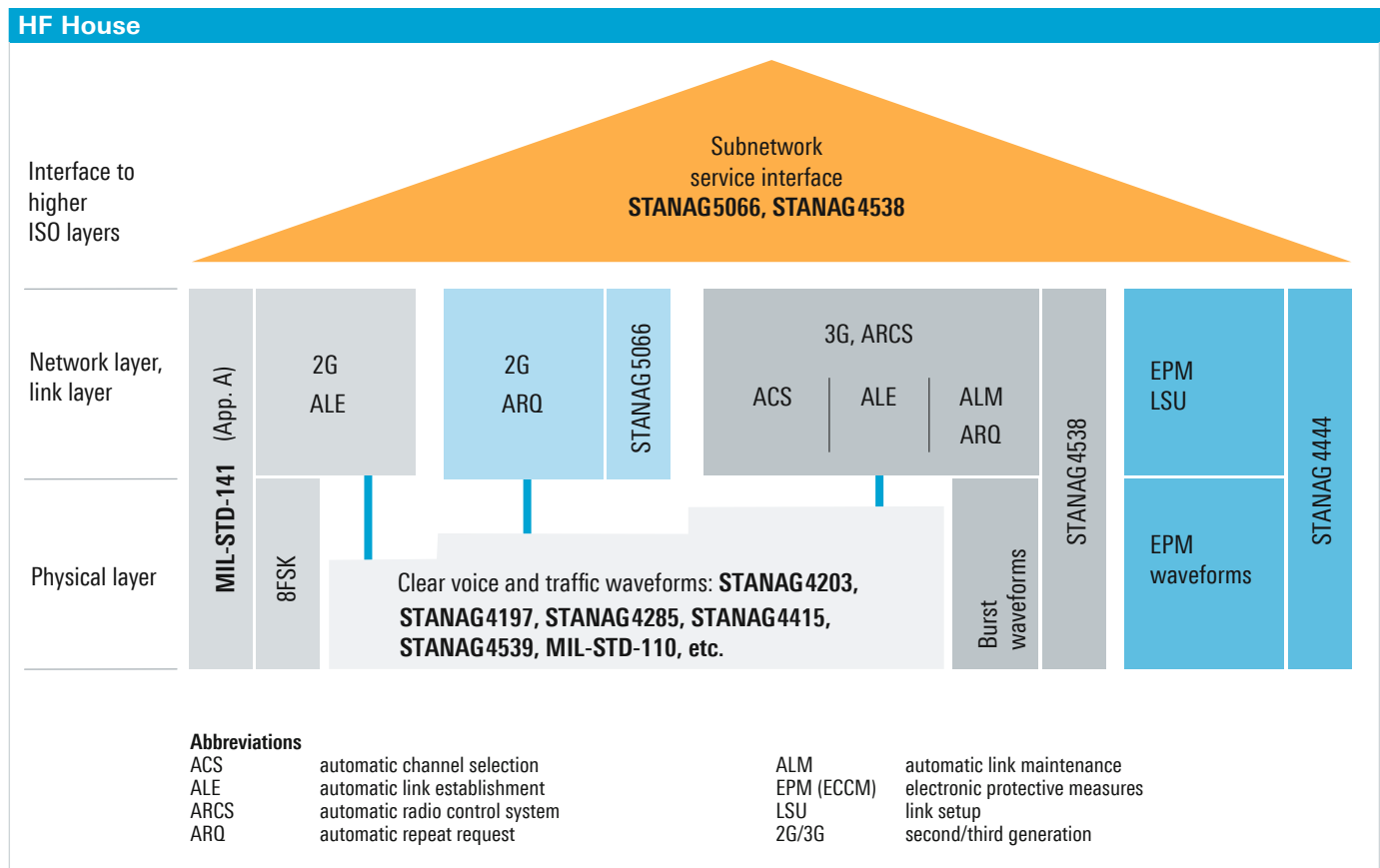

data link protocols. In addition, the automatic link maintenance (ALM) functionality is supported, allowing channels to be switched during a transmission without interrupting the link. The layer 2 protocols known as LDL (low-latency data link) and HDL (high-throughput data link) have the benefit of improved robustness at low S/N values compared to conventional protocols.

The ALE-3G xDL protocols permit ARQ-secured, channel-adaptive data transmission that has been optimized for the special characteristics associated with shortwave channels. Mechanisms such as code combining and packet aggregation optimize the data throughput. Due to its robustness, the LDL protocol can even transmit reliably in channels with a negative signal-to-noise ratio.

HF modem, R&S®GM4120S

The STANAG 4539 HF modem provides transmission data rates from 75 bit/s to 12800 bit/s. It is the recommended modem for new NATO projects. It automatically adapts the receiving data rate and is used preferably with the STANAG 5066 data protocol. STANAG 4539 complies with MIL-STD-188-110B section 5.3 + App. C. The STANAG 4539 implementation in the R&S®M3SR Series4100 performs significantly better than that of the competition and is robust in case of multipath propagation. STANAG 4539 includes the STANAG 4415 modem standard.

The STANAG 4285 HF modem is used primarily for broadcasting operation and for ARQ-secured data transmission, typically in conjunction with an external R&S®STANAG5066 application.

The MIL-STD-188-110B App. F waveform uses independent sidebands for high-speed data transmission with up to 19200 bit/s. It consists of two identical MIL-STD-188-110B App. C modems to double the available data rate.

STANAG 4529 is used in naval applications; it requires only 1240 Hz bandwidth to achieve data rates from 75 bit/s to 1200 bit/s.

STANAG 4481 is a conventional FSK and PSK waveform for navy applications and data rates from 50 bit/s to 600 bit/s. STANAG 5065 allows shore-to-ship broadcast reception using the low frequency band, in particular from 60 kHz to 160 kHz.

HF modem, R&S®GM4122S

This option activates the STANAG 4539 and STANAG 4285 modems as described above.

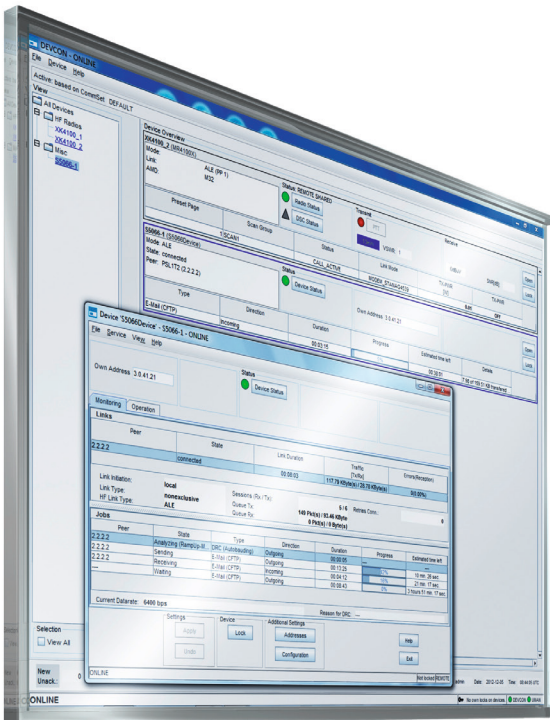

R&S®STANAG5066 is a communications solution for the robust and highly secure exchange of data using HF radio networks in line with STANAG5066. R&S®STANAG5066 uses the internal modems of R&S®M3SR Series4100 radio.

Secure and reliable communications

Due to the potentially worldwide propagation of an HF signal, it would be possible to eavesdrop on communications all over the world. In order to protect confidential transmissions effectively, the information must be encrypted.

Secure digital voice/data (SDV), R&S®GM4121S

SDV provides easy-to-use, versatile embedded encryption for fixed frequency connections as well as for connections established with ALE-3G.

When using ALE-3G's synchronous link establishment process, users profit from the combination of information security (SDV) and ALE-3G's inherent mechanisms for improving transmission security (linking security). In ALE-3G mode, the replay protection protects against spoofing attacks.

The Rohde&Schwarz RSCA crypto algorithm with a key length of up to 256 bits can be used for both voice and data connections. Either the voice information that has been digitized or the data, which is transmitted using LDL and HDL, is encrypted.

Last ditch voice

In order to ensure reliable connections in heavily disturbed channels, the radio must employ extremely robust transmission methods: A very good choice is the last ditch voice (LDV) technique from Rohde&Schwarz available for the R&S®M3SR Series4100 radio family.

With LDV, the digitized voice message is first stored temporarily in the transmitting radio. Then, the stored LDV message is sent. Messages are transmitted as a type of voice mail, and not in realtime. Instead, they are passed on to the receiver without error through the LDL protocol's ARQ. This takes place fully automatically after the transmitter has triggered the process. The receiver reports the arrival of a new message and stores it. The message can be called up as often as desired. Transmission of LDV messages is always encrypted.

Structure of the stack

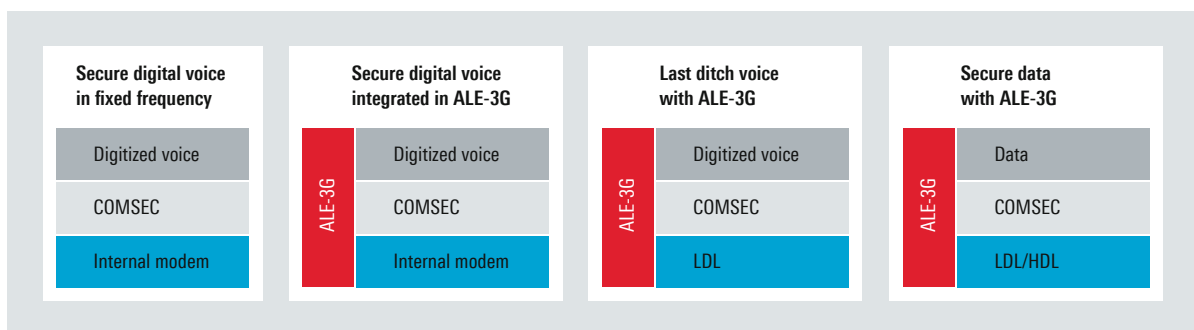

Structure of the stack for secure digital voice with and without ALE-3G link establishment and for last ditch voice.

R&S®SECOM-H EPM (ECCM), R&S®GS3001S

R&S®SECOM-H is a Rohde&Schwarz proprietary HF frequency hopping radiocommunications waveform similar to STANAG 4444. It is designed to operate in environments where a certain percentage of the hop set frequencies are blocked due to either intentional (i.e. jamming) or unintentional disturbances, as well as in environments with severe Doppler spread and/or multipath delay. In addition, it is based on modem waveforms that can be adapted to the specific characteristics of the HF channel and its propagation.

R&S®SECOM-H provides digital voice (low bit rate vocoder at 600 bit/s, 1200 bit/s or 2400 bit/s, adjustable) and data services (up to 2400 bit/s). To ensure reliable links even in severely degraded channels, free hop set search (FHS) is available. FHS is an algorithm for the automatic adaptation of hop sets based on channel evaluation. Radios in a point-to-point link will generate and use an advanced hop set containing only frequencies with proven good RF performance.

For network synchronization, GPS can be used as the network time source. GPS-based network time eliminates the need for manual net entry; all stations in the network remain synchronized as long as the GPS signal is received. Alternatively, the time can be exchanged over the air.

Management of black keys for additional security

The COMSEC/TRANSEC crypto algorithm was developed by Rohde&Schwarz. It supports key lengths up to 256 bits. Keys are generated using the R&S®CP3000 key management system. Keyset files are transmitted by the R&S®CP3000 to the R&S®RNMS3000 network management system using an additional asymmetric key protection key. This means that exclusively black keys are transported. Using the mission planner module, it is possible to set up secure R&S®SECOM-H radio networks consisting of the R&S®M3SR Series4100 and the R&S®M3TR. The R&S®SECOM-H radio configuration from the mission planner can be loaded into the radio via Ethernet or a fill device.

For SDV applications, the keys can also be generated using other solutions. In this case, the key can be entered directly into the radio.



Keys are generated using the R&S®CP3000 key management system.

Unrivaled radio parameters

A high frequency (HF) radio channel is a transmission medium that is characterized by time variance, low signal-to-noise (S/N) ratios, Doppler effects and multipath propagation. However, HF allows worldwide communications due to its unique propagation characteristics. To obtain usable signals, the operating frequencies and antennas as well as the radio parameters such as sensitivity, selectivity and noise suppression are essential.

Collocation capability due to excellent receiver specifications

Simultaneous operation of multiple radio lines on board ships is extremely challenging for the collocation capability of the radios due to the spatial proximity of the radios that results in low antenna decoupling values. However, due to the outstanding specifications of the radios of the R&S®M3SR Series4100, such challenges are easily surmounted. For HF parameters such as second and third-order intercept, desensitization and crossmodulation immunity, the R&S®M3SR Series4100 sets new standards. For example, even without preselection the receiver provides third-order intercept (IP3) of typically > 40 dBm. This parameter is particularly important in cases where very low amplitude signals must be reliably detected in the simultaneous presence of high-power interference from nearby transmitter systems.

Selective level control for optimum transmit power (software option)

Mutual influences between adjacent transmitter lines would cause a traditional transmitter to reduce its output power since the external power is taken into account as reflected power during VSWR calculation. The optional selective directional coupler available in the power amplifiers makes it possible to perform narrowband weighting of the transmit signal and the reflected antenna power. This means that the transmitter power control of the transmitter lines is not influenced during normal operation.

Digitally tuned RF selection (hardware option)

The optional HF pre/postselectors are steep-edged band-pass filters with a relative bandwidth of a few percent. They work at the transmitter and receiver ends and can be precisely set to the relevant operating frequencies. The HF pre/postselectors influence the performance of the radios in two ways. First, they reduce the TX phase noise to values better than typically -165 dBc (1 Hz). Second, they significantly increase the large-signal characteristics of the receive section, i.e. crossmodulation immunity, desensitization and second and third-order intercept points. The HF pre/postselector in the R&S®M3SR Series4100 supports frequency hopping.

Digital IF and audio signal processing

The R&S®M3SR Series4100 combines the unmatched dynamic range of radios with analog mixers with the latest in digital IF and audio signal processing. The second IF frequency of 48 kHz is sampled, digitized and processed using digital signal processors. This means that a wide range of IF bandwidths are available in all modes with high selectivity and optimized for voice and data communications. Digital signal processing also provides functions for noise suppression.



Rohde&Schwarz radios are used on board the ADCF frigate of the Royal Netherlands Navy.

Suitable for a wide range of situations

The R&S®M3SR Series4100 is extremely flexible and can be optimally adapted to a wide range of diverse deployment conditions. The logistics effort is low because the modular concept allows the use of many identical system components.

Three power classes and suitable line of accessories

The output power that is required of HF transceivers is highly dependent on the particular application scenario. The radios of the R&S®M3SR Series4100 are available in power classes of 150 W, 500 W and 1000 W. The R&S®M3SR Series4100 also includes a separate, standalone receiver. Without additional hardware, the R&S®M3SR Series4100 components can also be used to set up IP-based split-site systems. The product portfolio is rounded out by system components such as antenna tuning units (ATU) and dipole antennas from Rohde&Schwarz. For radio applications on ship and shore, broadband radio systems are also available. All components are designed to operate 24/7 within the rated temperature ranges at full output power.

HF broadband system

The HF broadband system is a flexible and modular multi-line radio system for the HF frequency range. The applications range from navy ships to shore radio stations with up to 32 radio lines. The system offers the full range of R&S®M3SR Series4100 modulation modes and waveforms, from simple SSB operation and ALE to EPM (ECCM) radio line. Intelligent radio line management provides flexible and dynamic allocation of transmit power, from a few watts to several kilowatts, to support a variety of military missions.

**See separate product brochure:
R&S®M3SR Series4100 HF broadband system
(PD 5214.1243.12).**



R&S®M3SR Series4100 software defined radios.

Easy operation

Rohde & Schwarz has extensive experience in stationary radio systems, which is reflected in the operating concept of the R&S®M3SR Series4100 radios. The displays and control elements are arranged in a user-friendly manner and are easy to understand.

Clear status display

All required settings on the radio can be made using the R&S®GB4000C control unit. The R&S®GB4000C can be integrated into the radio or it can control the radio remotely. It can also be used to operate several R&S®M3SR Series4100 radio systems (only one at a time) in an IP network.

Preconfigured menus

The user interface for the R&S®M3SR radio family has clearly structured menus that are organized by function. Each operating mode is set using preconfigured menus (preset pages). The R&S®M3SR Series4100 can manage up to 100 preconfigured menus. The configuration is generated using the R&S®RNMS3000 network management system. The preset pages can then be loaded into the radio via LAN, RS-232 or a flash device.

Radio configuration only by authorized personnel

The areas that contain the settings for maintenance and configuration of the radio are password-protected. This ensures that only authorized personnel can carry out maintenance or in-depth configuration of the radio. The password can be set in the R&S®RNMS3000 network management system.



The R&S®GB4000C control unit has a user-oriented GUI for intuitive radio operation.

Low maintenance effort

The R&S®M3SR Series4100 radios were developed with low maintenance effort in mind. A variety of control and monitoring functions are available that provide the user with detailed status information about the radios. In addition, built-in test functions permit service and maintenance tasks to be carried out in a targeted manner. The radio systems can be remotely analyzed, eliminating the need for on-site service. Resistance to vibrations and a wide operating temperature range allow the systems to be used in diverse applications.

Rugged design, suitable even for difficult environmental conditions

The radios fulfill the requirements stipulated in the MIL-STD-810F military standard for operating temperature and mechanical influences such as vibration and shock. The corresponding standard for electromagnetic compatibility is MIL-STD-461E.

Powerful built-in test (BIT)

Multiple test procedures support users in checking that the radio functions properly and in identifying any malfunction down to module level. BIT results can be displayed locally and also queried from a remote site.

The following built-in tests are supported:

- Power-on BIT (PBIT)
- Continuous BIT (CBIT)
- Initiated BIT (IBIT)

The PBIT is a short self-test that is automatically performed each time the radio is powered on. The CBIT continuously polls the status messages from all radio modules during regular operation.

The IBIT allows a functional check of the complete system. Besides the base unit, it also checks external system components such as power amplifiers, power supplies and any antenna tuning units that are connected. Failures and warnings are reported as plain text. The radio also shows the total operating time.

Excellent reliability

The R&S®M3SR Series4100 radios can operate in continuous-wave mode over a wide ambient temperature range from -20°C to $+55^{\circ}\text{C}$. If the temperature exceeds the permissible range, the transmitter will automatically and gradually decrease its output power in order to maintain operation. If ambient conditions return to normal, the transmitter will revert to normal operation without requiring any manual intervention.

Easy module exchange

All RF modules are equipped with LEDs showing the module status. Modules can easily be exchanged without recalibrating the radio.



View of the radio's interior.

IP-based radio-communications using R&S® Postman III

Communications in civil and military missions have undergone important changes in recent years. While voice communications continue to play an important role, data communications are increasingly gaining in significance. The R&S®M3SR Series4100 radios and R&S®Postman III form a future-oriented HF radiocommunications solution for IP-based data transmission.

Example of data transmission in civil and military radio networks.

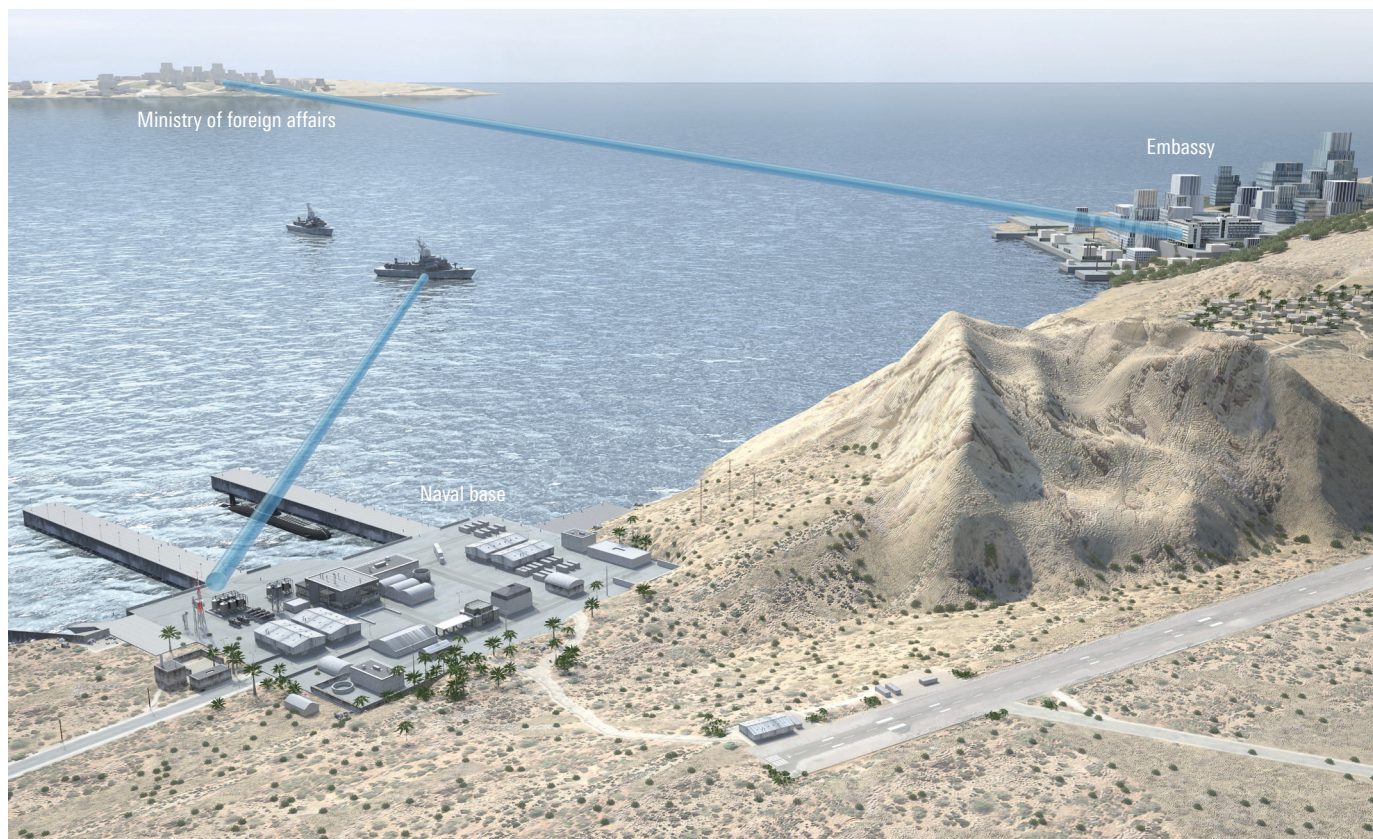

Civil and military information exchange

R&S®Postman III contributes to the success of military and civil missions by enabling efficient data transmission in radio networks. Such missions can occur in naval and coast guard scenarios, border controls, disaster situations or rescue operations. Organizations such as embassies and consulates frequently use wireline communications. In the event that this infrastructure fails, R&S®Postman III together with the R&S®M3SR Series4100 radios provides information exchange via shortwave. The combination of the STANAG 5066 radio protocol and the ability to handle STANAG 4539 and STANAG 4285 waveforms converts R&S®Postman III and the R&S®M3SR Series4100 radios into a radiocommunications system for interoperable military missions.

Optimized for HF communications

R&S®Postman III has been specially optimized for communications via HF radio networks with low or variable data transmission rates. R&S®Postman III supports the R&S®M3SR Series4100 and can send IP data directly to the radio. Special mechanisms in R&S®Postman III and the R&S®M3SR Series4100 control the data flow to prevent loss of data.

Multiline capability for simultaneous communications with multiple radio network participants

An R&S®Postman III system allows the simultaneous use of multiple different communications lines. Especially in radiocommunications, this means that information can be exchanged simultaneously with multiple participants over different radio networks. R&S®Postman III automatically selects a line suitable for communicating with the remote participant.

Simple and comprehensive communications applications

The most important applications are e-mail, chat, fax, voice mail and file transfer. Its position display capability makes R&S®Postman III a tool for generating situational awareness and performing blue force tracking. This is a crucial prerequisite for enabling coordinated action in both civil and military operations.

Split-site system

The R&S®M3SR Series4100 radio family supports IP-based split-site operation; no additional hardware is required.

Operation of high-power transmitters close to receivers at the same site, as occurs in broadcast and ship-to-shore (BRASS) applications, can cause interference to the receivers. In such cases, the transmitters and receivers are located at separate sites ("split-site operation"). In military environments too, it is common to install the transmitter and receiver systems as far as possible from the operational centers to help prevent precise position fixing of the operational centers and attacks against them.

Split-site operation with the R&S®M3SR Series4100

In the R&S®M3SR Series4100 family of software defined HF radios, the split-site controller functionality is entirely implemented in software and no special hardware is required. Standard radios from the R&S®M3SR Series4100 are used as the split-site transmitter and receiver. For data transfer between the split-site controller and the transmitter and receiver, the IP interface included in the radios is used. The figure shows a typical split-site system with these radios.

Split-site operation also supports complex waveforms such as automatic link establishment (ALE-2G/ALE-3G in accordance with STANAG 4538) as well as modem waveforms (e.g. STANAG 4285 and STANAG 4539). Of course, classic HF modes such as SSB (J3E) or AM (A3E) can also be used.

Split-site system with R&S®M3SR Series4100 radios

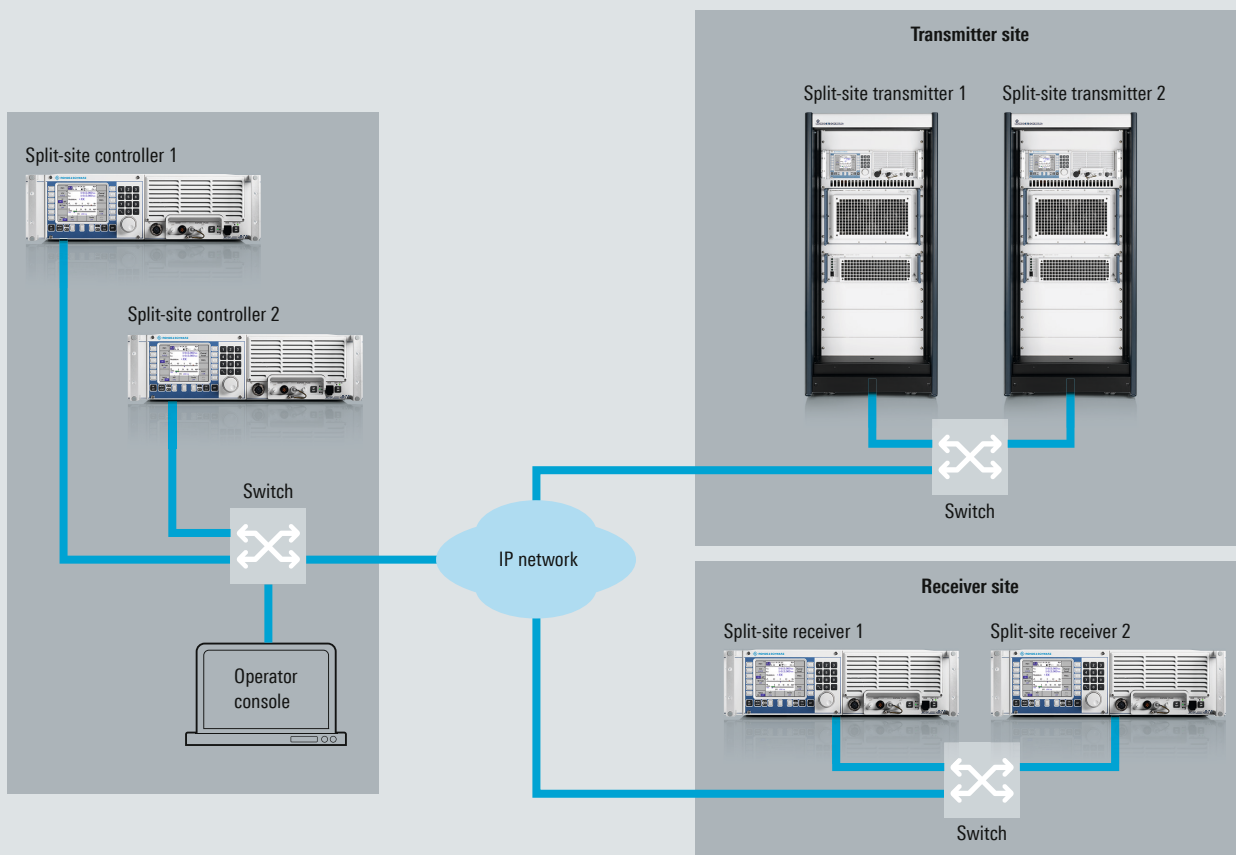

Support also for secure links

The interfaces in the R&S®M3SR Series4100 radios for data and remote control data are unchanged. Crypto devices and – if red/black separation of the control signals is required – a trusted filter (firewall functionality) can be used. Encryption is possible using external, commercially available IP security solutions.

High availability and flexibility

Communications links today are increasingly based on the Internet protocol, which is progressively replacing the classic analog and digital telecommunications links. One of the objectives in the development of IP was to enable the transport of data packets via alternative routes in case connections fail. With appropriate network planning, high availability can be ensured for the entire system.

The ability to assign a split-site controller dynamically to a certain transmitter and receiver offers great flexibility in configuring the overall system. This makes it possible to select the transmitters and receivers with the sites and antennas that are the best match for the current task. Usage of costly transmit antenna switches can be kept to a minimum by appropriate system design. Even if individual split-site components fail, the remaining components can be reallocated dynamically, which helps to improve overall availability.

Lower maintenance and logistics costs

Generally, each base unit in the R&S®M3SR Series4100 radio family (R&S®GX4100, R&S®EK4100 or R&S®XK4115) can be configured as a split-site controller by activating the R&S®GS4156S software option. The R&S®M3SR Series4100 radios used in the transmitter and receiver systems do not require any special hardware extensions for split-site operation. The table shows an example illustrating the benefits of configuration for split-site operation: A split-site radio line can be implemented using three identical R&S®GX4100 receivers/exciter. This is a significant benefit for users, simplifies logistics and saves on spare units.

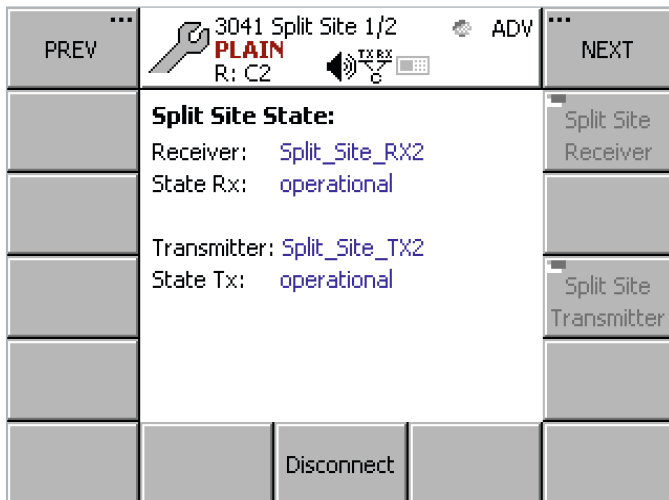

User interface for split-site configuration.

Possible hardware configuration for split-site operation with the R&S®M3SR Series4100 HF radios

Components	Hardware
Split-site transmitter	R&S®GX4100 (receiver/exciter) R&S®VK4190 (1000 W power amplifier) R&S®IN4190 (1000 W power supply)
Split-site receiver	R&S®GX4100 (receiver/exciter) R&S®IN4000A (power supply)
Split-site controller	R&S®GX4100 (receiver/exciter) R&S®IN4000A (power supply)

R&S®RNMS3000

radio network management system

Utilization planning, radio network configuration and data distribution

Increased significance for a radio network management system

In today's world, information exchange via voice and data is indispensable for military forces to fulfill their increasing mission requirements. Handling all these communications demands with their complex waveforms requires an extended network management system. By offering R&S®RNMS3000, Rohde & Schwarz provides such a radio network management system. It enables military leaders to turn their Rohde & Schwarz combat radio equipment into a robustly networked communications system based on mission demand and on complex hierarchical structures, especially in joint or combined missions. In the past, many parameters had to be adjusted on the radios, which required highly skilled users. In future, the configuration complexity will be done during the preparative configuration of a management system.

R&S®RNMS3000 – the convenient way to empower the capabilities of Rohde & Schwarz radios in networks

The R&S®RNMS3000 software supports centralized network management, where one central organizational unit performs the complete mission planning, as well as decentralized management, where the various configuration steps are accomplished on different military hierarchical levels. The R&S®RNMS3000 software suite, consisting of the mission planner, the remote device loader and the remote distributor, offers the following functions:

- Management of security keys
- Frequency assignments
- Establishment of logical nets
- Distribution of mission files

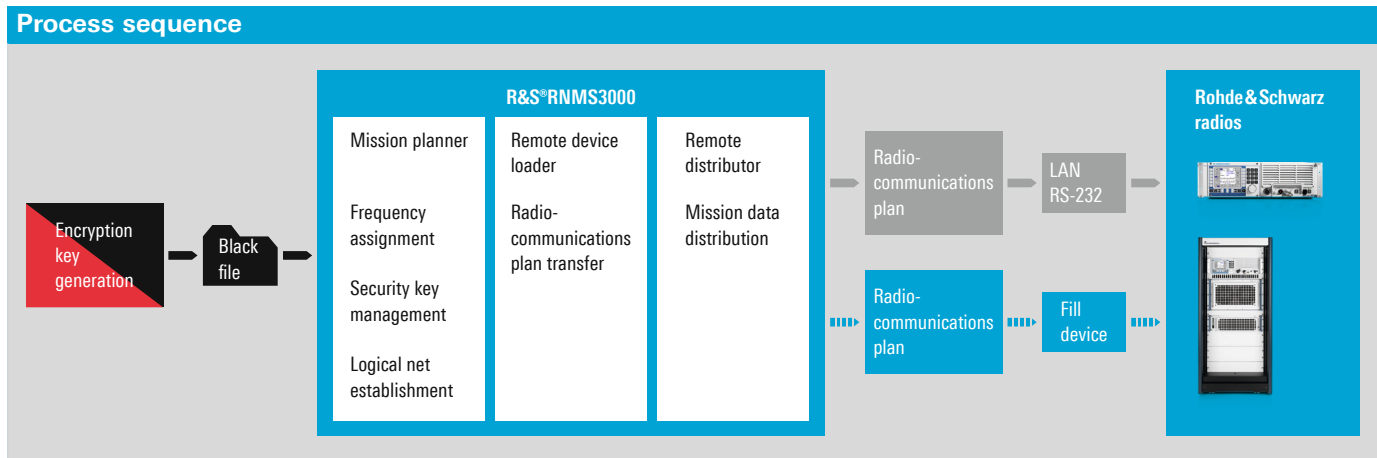

The objective is to provide mission-tailored and secured radiocommunications networks. Especially the R&S®RNMS3000 capability to manage NATO-specific waveforms, as well as general HF House waveforms and Rohde&Schwarz proprietary waveforms, underlines its broad range of applications.

Comprehensive waveform support

- NATO waveforms
- HF House waveforms
- R&S®SECOM waveform
- R&S®SECOS waveform

Highlights

- Support of all Rohde&Schwarz radios and all frequencies
- Support of voice and data services
- Network planning, mission file generation and distribution with one software suite
- Target-oriented software guidance with wizards

Key features

Mission planner – mission-tailored network planning

- Frequency assignment
- Hop set generation and management
- Security key management
- Efficient mission planning

Remote device loader – mission-optimized radio-communications plan transfer

- Secure file transfer
- Effective hardware programming

Remote distributor – extended mission data distribution

- File distribution over existing IP networks
- Event log and status control

Effective mission planning

The mission planner software allows mission-optimized and time-critical software use. The program provides target-oriented software navigation via wizards to allow operator mission planning with a focus on the essential parameters. In case of a configuration error, R&S®RNMS3000 displays a fault message including advice to support the error search process. The created mission file and configuration progress are saved automatically in a database to avoid losing critical mission data due to a hardware failure.

R&S®GP4100A fill device

The R&S®GP4100A fill device needs no power supply since it is supplied by either the connected PC or the radio. The fill device status is indicated by LEDs (power on, reading, writing, connected, error). After setting up a network configuration with R&S®RNMS3000, the generated configuration files are stored in the fill device via the USB interface of the PC running R&S®RNMS3000 and the remote data loader (RDL).

At the radio site, operator action is limited to choosing the appropriate radio global address (RGA) in the radio HMI to assign a radio to its preconfigured configuration. All files transferred from and to the fill device are encrypted before loading. Sensitive data such as keys is therefore stored in the fill device in black form only.



R&S®GP4100A fill device for R&S®M3SR Series4100 radios.

System overview

Logistical structure

The logistical structure of the R&S®M3SR Series4100 is based on radio models that are available for the R&S®EK4100 receiver, the R&S®GX4100 receiver/exciter and the R&S®XK4115 150 W transceiver.

Each radio model consists of:

- Hardware base unit
- Radio software
- Software and hardware options

The base units, known as R&S®MR4100x, are all ruggedized with a splashproof IP32 front panel. The radio software for these base units can be ordered in the form of “A” software (with no export restrictions) or “D” software (requiring an export license).

Depending on customer requirements, individual hardware and software options can be added to the system (see product overview).

The final type designation and the order number for a custom-configured R&S®EK4100A/R&S®EK4100D or R&S®XK4115A/R&S®XK4115D are order-specific. This makes it possible to clearly identify any customized unit with all of its options using a unique order number.

R&S®M3SR Series4100 power classes

R&S®EK4100A/D receiver



R&S®XK4115A/D 150 W transceiver



500 W transceiver systems



R&S®GX4100A/D
HF receiver/exciter

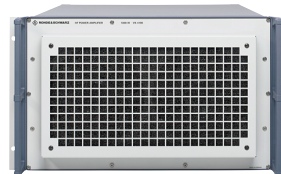

R&S®VK4150
500 W HF power amplifier



R&S®IN4150 power supply

1000 W transceiver systems



R&S®GX4100A/D
HF receiver/exciter

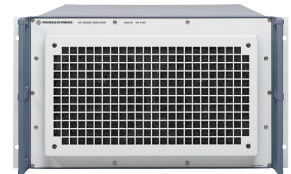

R&S®VK4190
1000 W HF power amplifier



R&S®IN4190 power supply

R&S®IN4000A power supply



R&S®EK4100A/ R&S®EK4100D VLF-HF receiver

The R&S®EK4100A/R&S®EK4100D VLF-HF receiver provides an internal AC power supply for operation on 110 V to 230 V AC voltage. Alternatively, it can be operated on 28 V DC voltage.

Key features

- ▮ Frequency and channel scanning
- ▮ IP3 > 40 dBm
- ▮ Latest DSP technology
- ▮ 10 kHz to 30 kHz reception
- ▮ High sensitivity
- ▮ Full remote control via IP or RS-322
- ▮ Audio via IP or analog
- ▮ Modular concept

R&S®EK4100A/D

R&S®DS4100A/D
radio software

Software options

Hardware options

R&S®MR4100E
VLF-HF receiver
(base unit)

R&S®EK4100A/D VLF-HF receiver: front view



Control panel

Fill-device
interface

Headset
connector

Indicators

Power on/off

Erase

R&S®EK4100A/D VLF-HF receiver: rear view

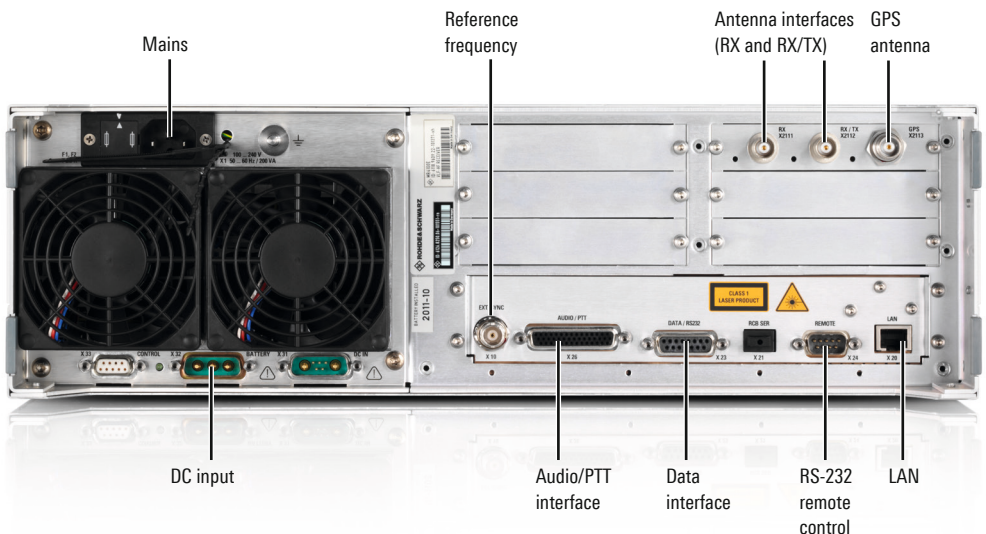

Mains

Reference
frequency

Antenna interfaces
(RX and RX/TX)

GPS
antenna

DC input

Audio/PTT
interface

Data
interface

RS-232
remote
control

LAN

R&S®XK4115A/ R&S®XK4115D 150 W transceiver

The R&S®XK4115 has a built-in 150 W power amplifier. The transceiver can be operated on 28 V DC voltage or, with an external R&S®IN4000A power supply, on 230 V AC voltage.

In addition to the receive characteristics it shares with the R&S®EK4100A/R&S®EK4100D, the transceiver offers the following noteworthy features:

- ▮ 24/7 operation (TX at +55 °C)
- ▮ Link operation ready
- ▮ Frequency hopping capability

R&S®IN4000A external power supply

The R&S®IN4000A features a wide AC input range that provides robust protection against AC voltage fluctuations. A sophisticated voltage regulation concept ensures highly stable DC output voltage regardless of load fluctuations and ambient temperature variations.

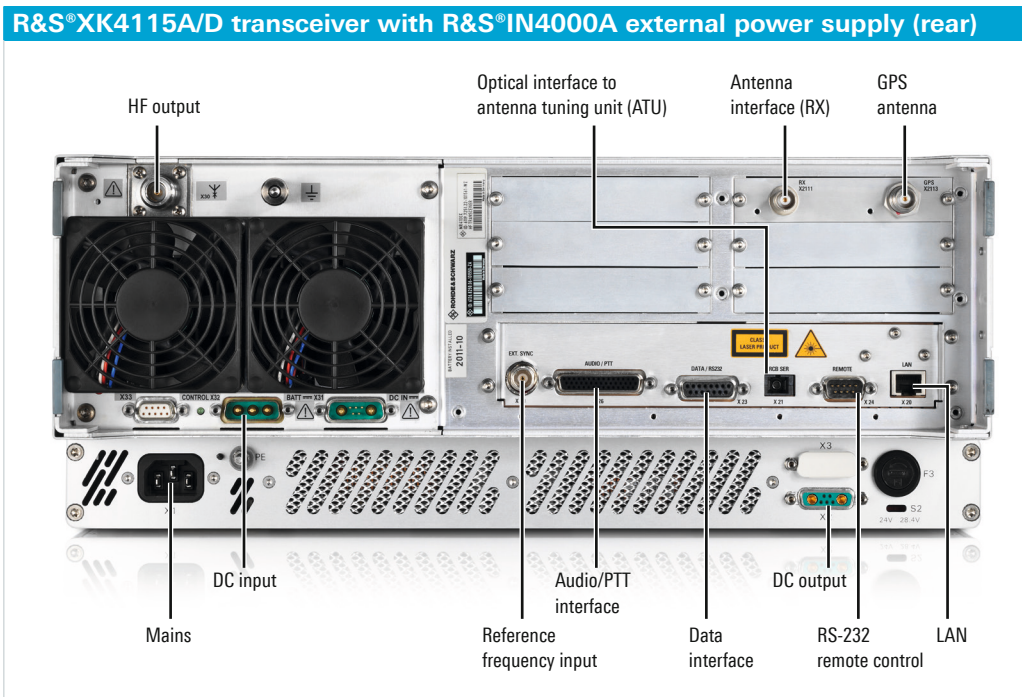
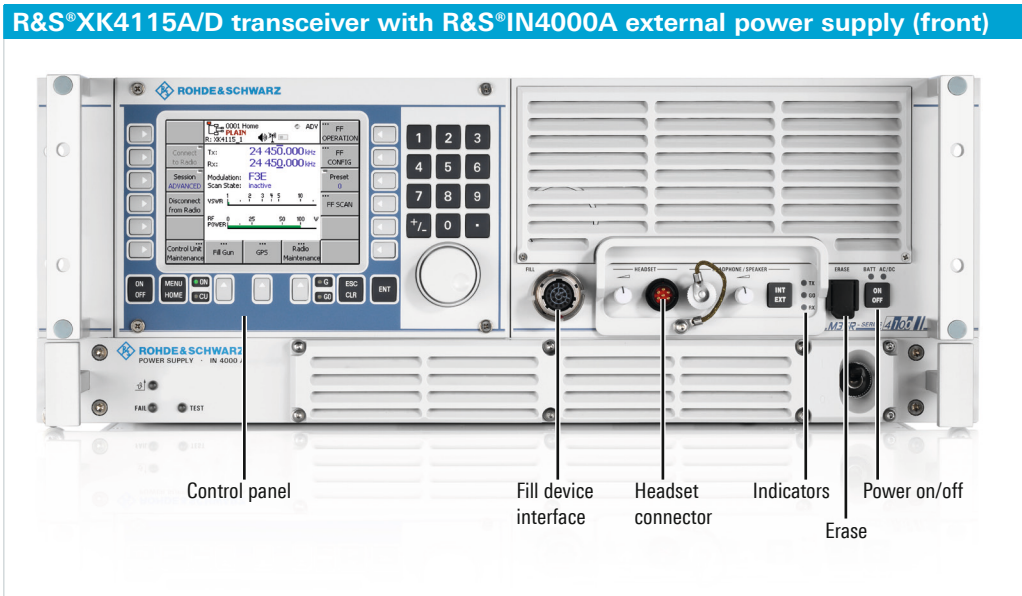
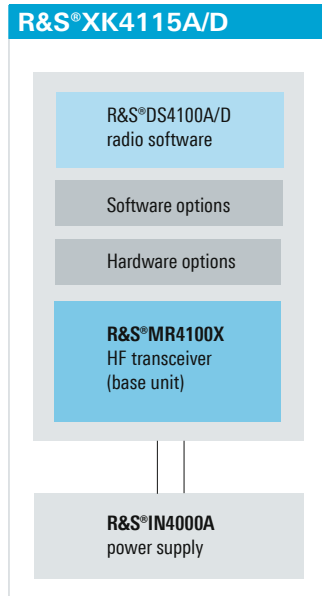

500 W/1000 W transceiver systems

To cover large distances, transceiver systems with an output power of 500 W and 1000 W are available. These solutions provide exceptionally high radio link availability – even under moderate propagation conditions.

They provide higher signal-to-noise ratios as required when transmitting at high data rates, for applications in worldwide embassy radio systems, in civil ATC systems or in the military. It also goes without saying that these systems offer frequency hopping capability.

A 500 W or 1000 W transceiver system consists of the following components:

- R&S®GX4100A/R&S®GX4100D receiver/exciter
- R&S®VK4150/R&S®VK4190 power amplifier
- R&S®IN4150/R&S®IN4190 power supply

R&S®GX4100A/R&S®GX4100D receiver/exciter

The R&S®GX4100A/R&S®GX4100D controls the R&S®VK4150/R&S®VK4190.

R&S®GX4100A/D

R&S®DS4100A/D
radio software

Software options

Hardware options

R&S®MR4100G
HF receiver/exciter
(base unit)

R&S®GX4100A/R&S®GX4100D receiver/exciter: front view



R&S®GX4100A/R&S®GX4100D receiver/exciter: rear view

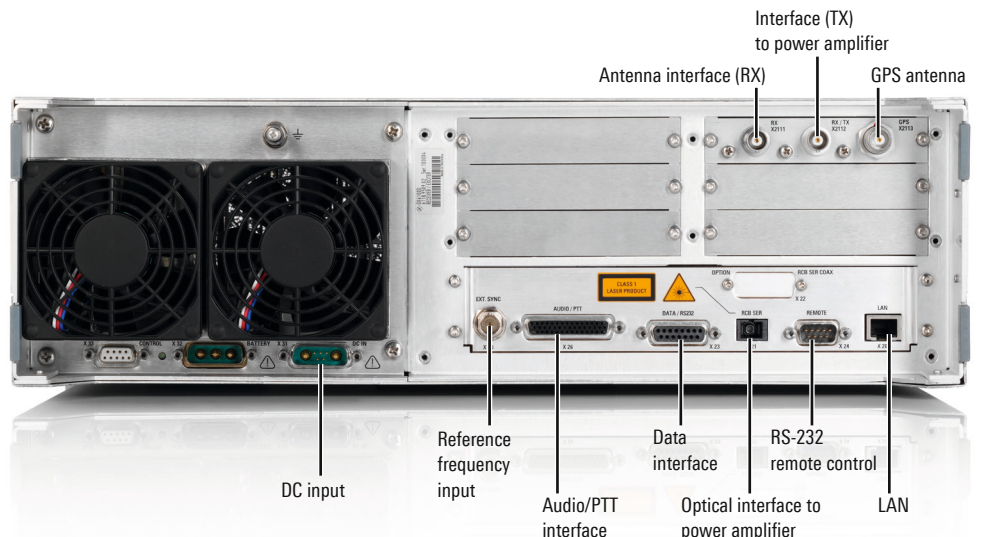

R&S®VK4150/R&S®VK4190 power amplifier

The digitally controlled R&S®VK4150/R&S®VK4190 power amplifier is available as a standard model and a special model with built-in receiver input protection. The receiver input protection protects the receiver input from destruction through HF interference on the antenna. The built-in receiver input protection should be selected whenever undisturbed reception of wanted signals is required under extreme conditions.

- ▮ 24/7 operation at full output power (100% duty cycle) even at +55 °C
- ▮ Rugged design, high MTBF
- ▮ Software option for selective level control available

R&S®IN4150/R&S®IN4190 standard power supply

The R&S®IN4150/R&S®IN4190 standard power supply is controlled by the R&S®VK4150/R&S®VK4190 power amplifier. The control connection ensures that the power amplifier and the power supply always operate in the most efficient mode possible.

- ▮ Different models available for all conventional electrical networks
- ▮ High efficiency (up to 90%)
- ▮ State-of-the-art power factor correction (> 95%)
- ▮ Automatic switchover between AC and battery supply in case of power failure

R&S®VK4150/R&S®VK4190 power amplifier: front and rear view

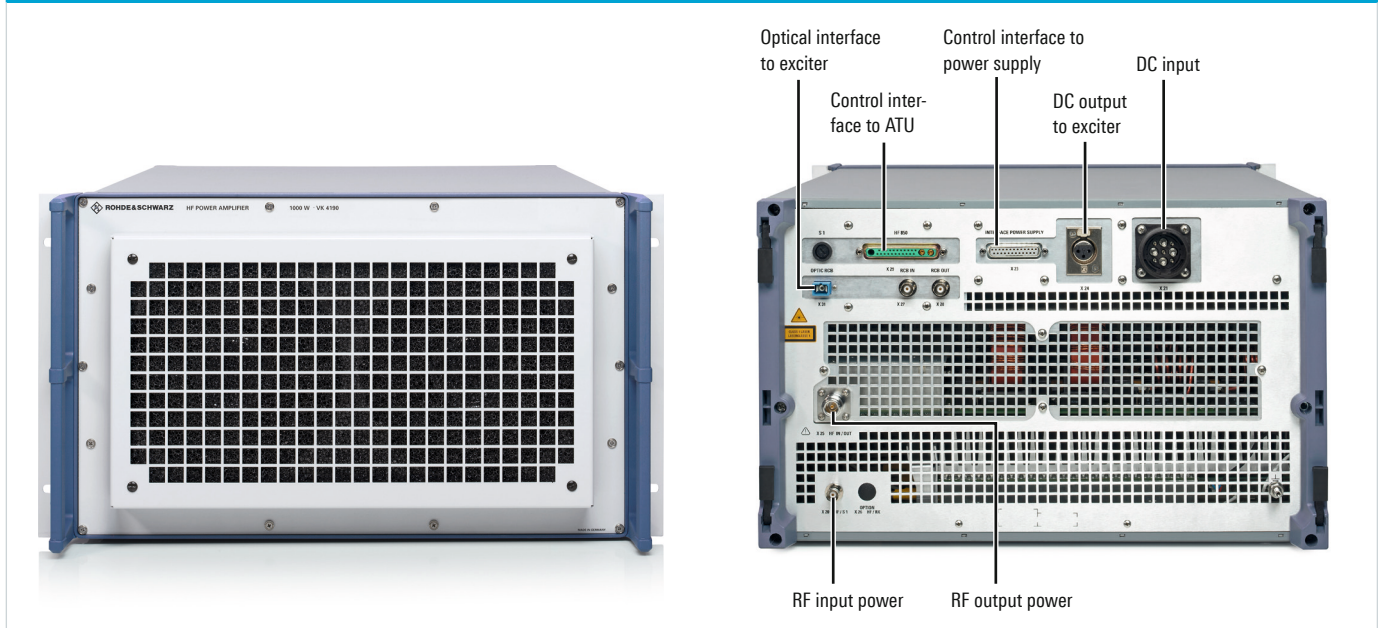

R&S®IN4150/R&S®IN4190 power supply: front and rear view

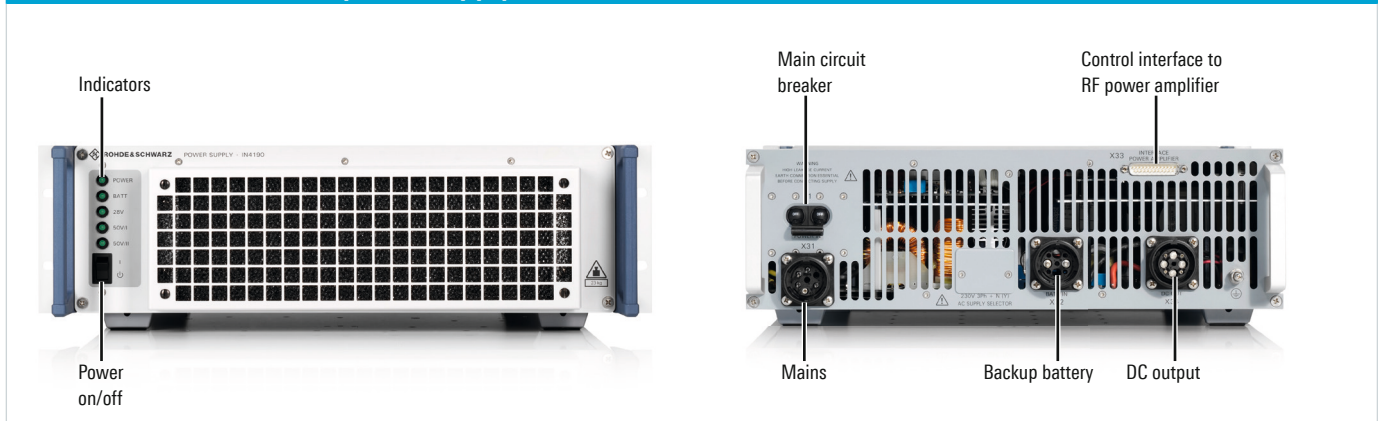

Antenna tuning units

All Rohde & Schwarz antenna tuning units (ATU) operate in the frequency range from 1.5 MHz to 30 MHz, where an antenna impedance transformation into 50 Ω in both the receive and transmit modes is performed. Additionally, Rohde & Schwarz ATUs provide preselection in the receive mode.

Key features

Silent tuning functionality

The Rohde & Schwarz antenna tuning units (ATU) offer a silent tuning feature over the entire frequency range from 1.5 MHz to 30 MHz. The advantage for the user is low probability of intercept (LPI), since Rohde & Schwarz ATU frequency setting is performed very quickly and without any emission of RF power.

Before this feature can be used, the Rohde & Schwarz ATUs must be connected to the antenna to “learn” its characteristic. Learning takes place in a user-defined frequency range within the HF band (1.5 MHz to 30 MHz).

Maintenance-free, rugged design

The rugged design of the Rohde & Schwarz ATUs allows them to be operated 24 hours a day.

BITE

The Rohde & Schwarz ATUs are included in the continuous monitoring of the entire system so that deviations from the normal operating status are displayed on the control unit.

EMC and overvoltage protection

All circuit boards are equipped with EMC filters. For protection against overvoltage as produced by lightning strikes to the antenna, the Rohde & Schwarz ATU’s output is provided with lightning protection. All antenna tuning units are tested to withstand arcs of 10 kV/10 kA.

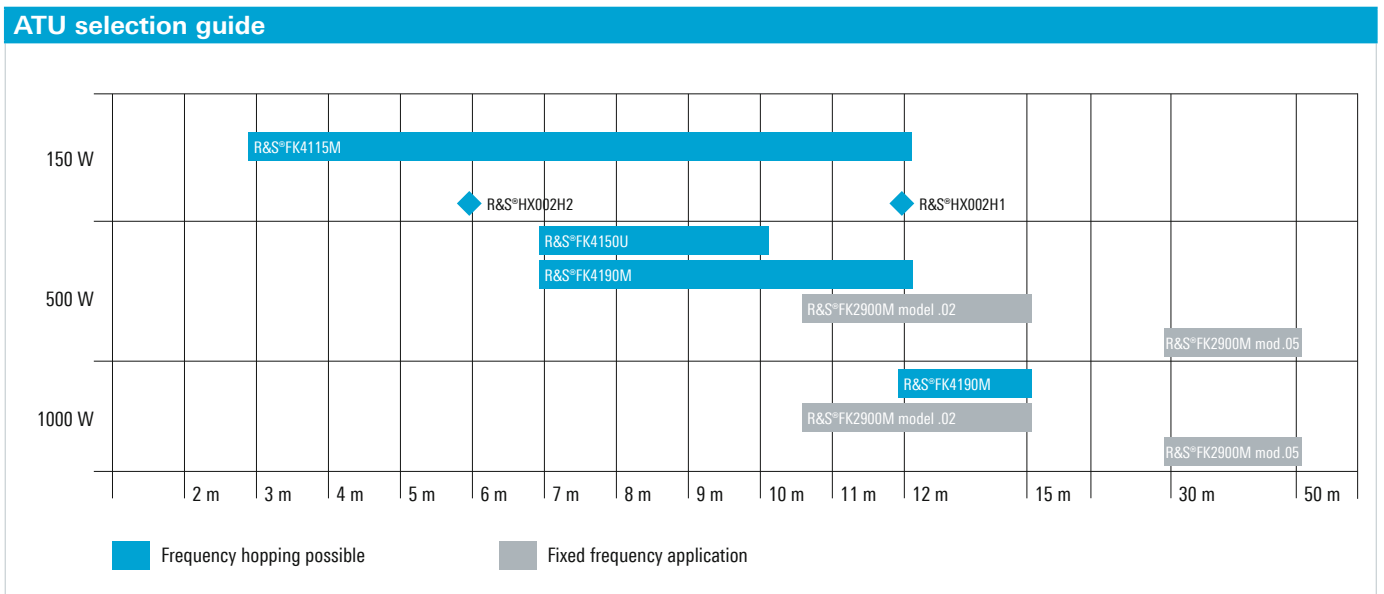
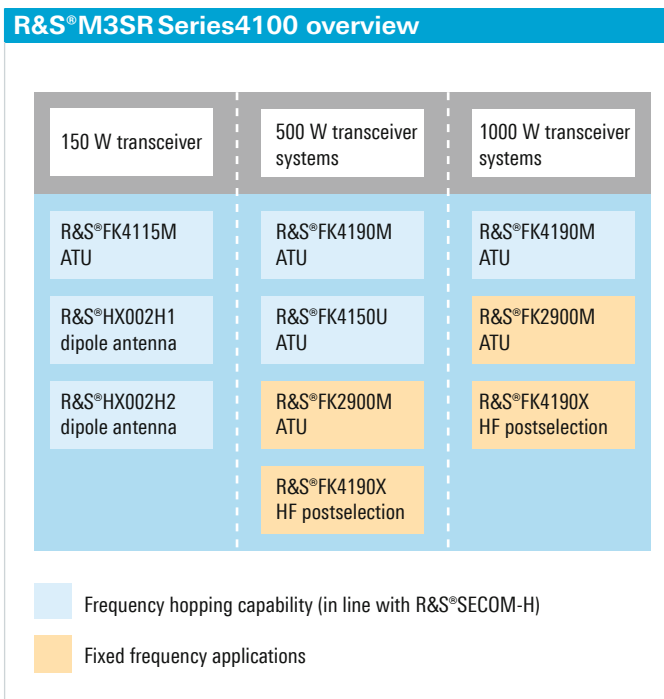

R&S®FK4115M HF antenna tuning unit

The R&S®FK4115M matches rod, whip and wire antennas (as used in naval and stationary applications) to the RF output of the 150 W transceiver of the R&S®M3SR Series4100. The antenna tuning unit (ATU) can handle up to 150 W PEP or 100 W CW at a 100% duty cycle.

The R&S®FK4115M has an extremely fast setting time for silent channels and allows frequency hopping operation in line with R&S®SECOM-H.

- Silent tuning over the entire frequency range from 1.5 MHz to 30 MHz
- Tuning of rod, whip and wire antennas
- 150 W PEP, 100 W CW at 100% duty cycle
- Frequency hopping capability (R&S®SECOM-H)
- Once the tuning data for these frequencies is known and stored, the silent setting time of the ATU is < 5 ms
- If the required VSWR (< 1.5:1) is not attained, the ATU can be retuned (nonsilent mode) in < 100 ms (typ.)

R&S®FK4150U HF antenna tuning unit

The R&S®FK4150U matches rod, whip and wire antennas (as used in submarine applications) to the RF output of the 500 W transceiver systems of the R&S®M3SR Series4100. The antenna tuning unit (ATU) can handle up to 500 W PEP and CW with rod/whip antennas of 7 m to 10 m length.

The R&S®FK4150U has an extremely fast setting time for silent channels and allows frequency hopping operation in line with R&S®SECOM-H.

- Silent tuning over the entire frequency range from 1.5 MHz to 30 MHz
- Tuning of rod, whip and wire antennas
- 500 W CW and PEP with 7 m to 10 m rod/whip antennas
- Frequency hopping capability (R&S®SECOM-H)
- Once the tuning data for these frequencies is known and stored, the silent setting time of the ATU is < 5 ms
- If the required VSWR (< 1.5:1) is not attained, the ATU can be retuned (nonsilent mode) in < 100 ms (typ.)

R&S®FK4115M HF antenna tuning unit.



R&S®FK4150U HF antenna tuning unit.

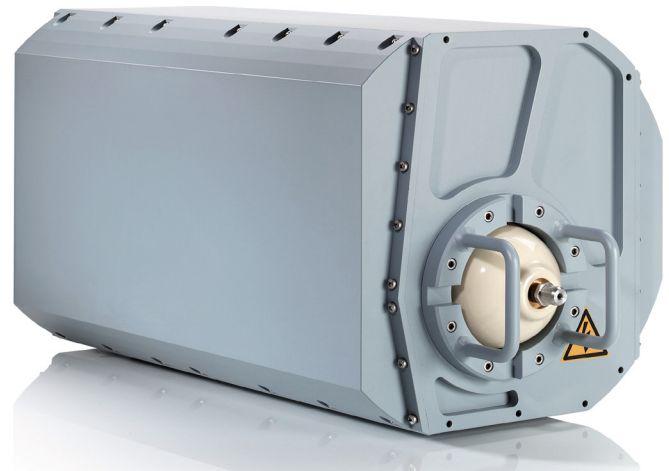

R&S®FK4190M HF antenna tuning unit

The R&S®FK4190M matches rod/whip and wire antennas (as used in naval applications) to the RF output of the 500 W and 1000 W transceiver systems of the R&S®M3SR Series4100.

The antenna tuning unit (ATU) can handle up to 500 W CW and PEP with rod/whip antennas of 7 m to 11 m length and up to 1000 W with 12 m rod antennas. Additionally, it provides preselection in the receive mode. The R&S®FK4190M has an extremely fast setting time for silent channels and allows frequency hopping operation in line with R&S®SECOM-H.

- Silent tuning over the entire frequency range from 1.5 MHz to 30 MHz
- Tuning of rod/whip antennas of 7 m to 11 m length
- 500 W CW and PEP at 100% duty cycle
- 1000 W CW and PEP (12 m rod antennas only)
- Frequency hopping capability (R&S®SECOM-H)
- Once the tuning data for these frequencies is known and stored, the silent setting time of the ATU is < 5 ms
- If the required VSWR (< 1.5:1) is not attained, the ATU can be retuned (nonsilent mode) in < 100 ms (typ.)

R&S®FK2900M 1 kW HF antenna tuning unit

The R&S®FK2900M matches the amplifier outputs of the transceivers to rod and wire antennas. It is designed for stationary or shipboard applications.

- Silent tuning over the entire frequency range from 1.5 MHz to 30 MHz
- Tuning of all rod antennas from 10.5 m to 12 m
- Tuning of long-wire antennas
- 1000 W CW and PEP at 100% duty cycle
- Once the tuning data for these frequencies is known and stored, the ATU setting time is < 40 ms
- If the required VSWR (< 1.5:1) is not attained, the ATU can be retuned in < 200 ms

R&S®FK4190M HF antenna tuning unit.

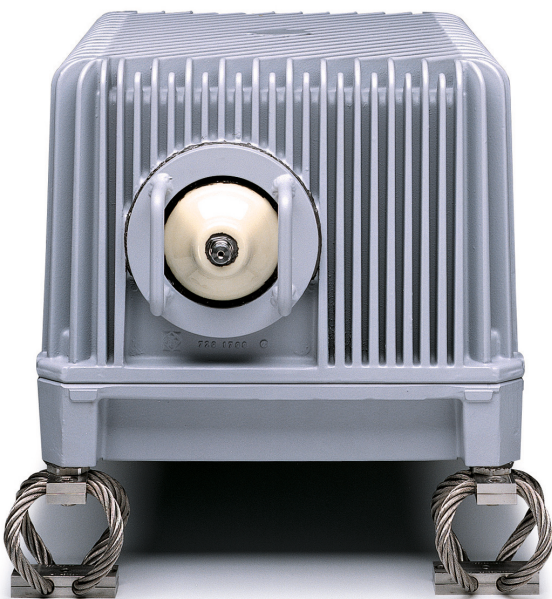

R&S®FK2900M 1 kW HF antenna tuning unit.



Dipoles and postselector

R&S®HX002H1/R&S®HX002H2 150 W HF dipoles

The R&S®HX002H1 and R&S®HX002H2 150 W HF dipoles are suitable for setting up radio links over any distance. In particular, the optimized omnidirectional coverage ensures high transmission reliability over short and medium distances.

- Silent tuning over the entire frequency range from 1.5 MHz to 30 MHz
- Integrated tuning unit for dipole
 - 12 m dipole version (H1) optimized for base station use
 - 6 m dipole version (H2) optimized for naval applications
- 150 W CW and PEP
- Frequency hopping capability (R&S®SECOM-H)
- Once the tuning data for these frequencies is known and stored, the silent setting time of the ATU is < 5 ms

R&S®FK4190X 1 kW HF postselector

This filter with a power rating of 1000 W is used together with the 500 W and 1000 W transceiver systems for suppressing mutual interference that may occur with co-sited transmit and receive antennas. It is mainly used for shipborne applications in order to meet collocation requirements if space for antennas is limited.

When connected between the transceiver and the ATU, the filter effectively suppresses spurious emissions due to its high selectivity of 30 dB (20 dB for $f > 15$ MHz) at $f \pm 10\%$. Tuning is digital by means of RF relays.

- Covers the entire frequency range from 1.5 MHz to 30 MHz
- 1000 W CW and PEP at 100% duty cycle
- Reduces transmitter noise
- Reduces harmonics

Typical three-dimensional radiation patterns

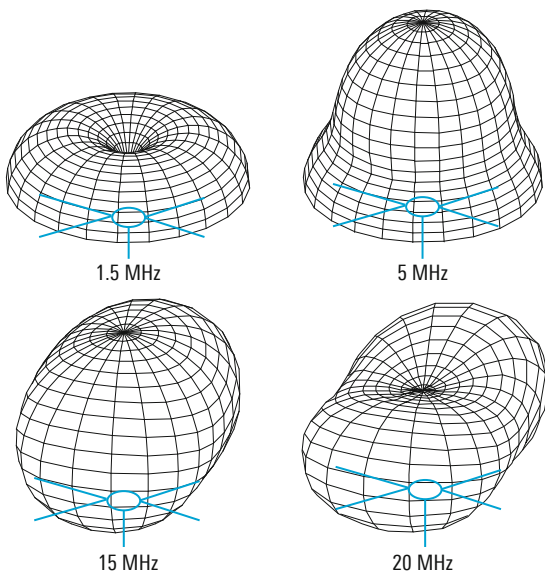

Typical three-dimensional radiation patterns above perfectly conducting ground.

R&S®HX002H1 150 W HF dipole.



R&S®FK4190X 1 kW HF postselector.



Software and hardware options



Description of software options

Type	Designation, description	Available for software	
		R&S® DS4100D ¹⁾	R&S® DS4100A ²⁾
R&S®GM4120S	HF modem Single-tone modems in line with STANAG 4285, STANAG 4539, MIL-STD-188-110B section 5.3 + App. C, STANAG 4529, STANAG 4481, STANAG 5065, MIL-STD-188-110B App. F.	•	
R&S®GM4121S	Secure digital voice/data SDV enables encrypted connections in fixed frequency channels. In combination with ALE-3G/STANAG 4538 (in this case the R&S®GS4155S or R&S®GS4165S option is additionally required), both secure voice transmission and secure data transmission are supported.	•	•
R&S®GM4122S	HF modem Single-tone modems in line with STANAG 4285, STANAG 4539, MIL-STD-188-110B section 5.3 + App. C.		•
R&S®GM4158S	Multitone Support of external multitone HF modems such as DRM modems.		•
R&S®GS3001S	R&S®SECOM-H EPM (ECCM) waveform This option activates the R&S®SECOM-H frequency hopping waveform.	•	
R&S®GS4101S	ALE-2G This option activates the support for second-generation automatic link establishment (ALE) systems. This software option provides support for the FED-STD-1045/1046/1049 and MIL-STD-188-141B App. A+B standards.	•	•
R&S®GS4114S	LINK software This option makes the radio parameters comply with the STANAG 5511, STANAG 5522 and MIL-STD-188-203-1A standards. External LINK 11 as well as LINK Y or LINK 22 modems (fixed frequency) can be connected directly to the radio.	•	
R&S®GS4115S	Selective level control The selective level control option for the 500 W and 1000 W power amplifier makes it possible to perform narrowband weighting of the transmit signal and the reflected antenna power. This ensures that transmitter power control is not influenced by extraneous signals during normal operation.	•	•
R&S®GS4117S	CE conformity mark HF system CE conformity (in line with EN 300373-1/-2/-3) means that the TX bandwidth must be limited and the output power reduced to 400 W for frequencies up to 4 MHz.	•	•
R&S®GS4155S	ALE-3G This option activates the STANAG 4538 waveform which includes: <ul style="list-style-type: none"> ■ ALE-3G (including ALE-2G) and ALM (for ALE-3G) ■ IP-optimized ARQ xDL protocols In order to use ALE-3G with embedded encryption for data and voice, the SDV (R&S®GS4121S) option key has to be installed.	•	
R&S®GS4156S	Split site Software for IP-based split-site operation.	•	•
R&S®GS4157S	RSS-181 conformity This option activates the SSB transmission bandwidth to comply with the Canadian RSS-181 standard.	•	•
R&S®GS4165S	ALE-3G This option activates the STANAG 4538 waveform which includes: <ul style="list-style-type: none"> ■ ALE-3G (including ALE-2G) and ALM (for ALE-3G) ■ IP-optimized ARQ xDL protocols In order to use ALE-3G with embedded encryption for data and voice, the SDV (R&S®GS4121S) option key has to be installed.		•

¹⁾ D version of radio software: export license required.

²⁾ A version of radio software: without export restrictions.

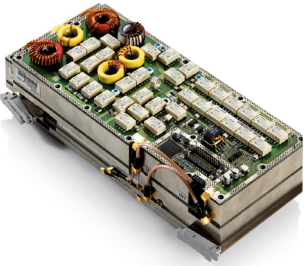
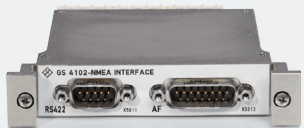
Description of hardware options

Type	Designation, description	Available for		
		R&S® MR4100E	R&S® MR4115X	R&S® MR4100G
R&S®GB4000C 	Control unit The R&S®GB4000C control unit is used for controlling, configuring and monitoring R&S®M3SR radios via Ethernet. The R&S®GB4000C is available as a standalone remote control unit and as an embedded local control panel. The control panel comes as a ruggedized model for demanding environmental conditions. A separate data sheet is available.	•	•	•
R&S®FK4120, R&S®FK4140 	RF selection, 20 dB Digitally tuned tracking bandpass filter (1.5 MHz to 30 MHz) with 20 dB edge steepness at 10% frequency offset. The R&S®FK4120 digitally tuned RF selection increases the selectivity of the transmit and receive paths. Receiver parameters such as second and third-order intercept, IF rejection, image frequency rejection and crossmodulation immunity are significantly improved. In the transmit direction, the TX phase noise is suppressed to produce typical values as low as -165 dBc (1 Hz). The digitally tuned RF selection is recommended for receiving low-amplitude signals in the simultaneous presence of strong HF carrier signals. This is the case when multiple HF radio lines operate simultaneously and independently of one another and reception should be possible even if adjacent lines are transmitting.	•	•	•
	RF selection, 40 dB Digitally tuned tracking bandpass filter (1.5 MHz to 30 MHz) with 40 dB edge steepness at 10% frequency offset. The R&S®FK4140 digitally tuned RF selection increases the selectivity of the transmit and receive paths. Receiver parameters such as second and third-order intercept, IF rejection, image frequency rejection and crossmodulation immunity are significantly improved. In the transmit direction, the TX phase noise is suppressed to produce typical values as low as -165 dBc (1 Hz). The digitally tuned RF selection is recommended for receiving low-amplitude signals in the simultaneous presence of strong HF carrier signals. This is the case when multiple HF radio lines operate simultaneously and independently of one another and reception should be possible even if adjacent lines are transmitting.	•	•	•
R&S®GS4102 	NMEA interface The NMEA (DSC) interface is necessary when the R&S®M3SR Series4100 transceiver systems are used to forward distress calls located by an external GMDSS monitoring and communications system.		•	•
R&S®GP4100A 	Fill device The fill device is used to transfer configuration data to one or more R&S®M3SR Series4100 radios.	•	•	•

Overview of hardware and software options

Type	Available for					
	Receiver		150 W transceiver		500 W/1000 W system	
Radio	R&S®EK4100A	R&S®EK4100D	R&S®XK4115A	R&S®XK4115D	R&S®GX4100A	R&S®GX4100D
Base unit	R&S®MR4100E		R&S®MR4115X		R&S®MR4100G	
Radio software	R&S®DS4100A	R&S®DS4100D	R&S®DS4100A	R&S®DS4100D	R&S®DS4100A	R&S®DS4100D
Hardware option						
R&S®GB4000C local control unit	•	•	•	•	•	•
R&S®FK4120 digitally tuned RF selection, 20 dB	•	•	•	•	•	•
R&S®FK4140 digitally tuned RF selection, 40 dB	•	•	•	•	•	•
R&S®GS4102 NMEA (DSC) interface			•	•	•	•
Software option						
R&S®GM4120S HF modem		•		•		•
R&S®GM4121S secure digital voice/data	•	•	•	•	•	•
R&S®GM4122S HF modem	•		•		•	
R&S®GS3001S SECOM-H		•		•		•
R&S®GS4101S ALE-2G	•	•	•	•	•	•
R&S®GS4114S LINK software		•		•		•
R&S®GS4115S selective level control (PA)					•	•
R&S®GS4117S CE conformity mark			•	•	•	•
R&S®GS4155S ALE-3G/STANAG4538 including ALE-2G		•		•		•
R&S®GS4156S split site	•	•	•	•	•	•
R&S®GS4157S RSS-181 conformity			•	•	•	•
R&S®GS4158S multitone support	•		•		•	
R&S®GS4165S ALE-3G/STANAG4538 including ALE-2G	•		•		•	

Product overview

Designation	Type
R&S®EK4100A/R&S®EK4100D receiver	
Base unit	
VLF-HF Receiver, AC/DC, without local control panel and radio software	R&S®MR4100E
R&S®XK4115A/R&S®XK4115D transceiver	
Base unit	
HF Transceiver, 150 W, DC, without local control panel and radio software	R&S®MR4100X
Power supply units	
External Power Supply, AC/DC, ruggedized model	R&S®IN4000A
500 W and 1000 W transceiver systems	
Base unit	
HF Receiver/Exciter, DC, without local control panel and radio software	R&S®MR4100G
Power amplifiers	
500 W HF Power Amplifier	R&S®VK4150
500 W HF Power Amplifier, with receiver input protection	R&S®VK4150
1000 W HF Power Amplifier	R&S®VK4190
1000 W HF Power Amplifier, with receiver input protection	R&S®VK4190
Power supply units for 500 W and 1000 W transceiver system	
Power Supply, 230 V AC, 1 or 3 phases + N/208 V AC, 3-phase Δ	R&S®IN4150
Power Supply, 440 V AC, 3 phases (used together with an R&S®BV4190 transformer)	R&S®IN4150
Power Supply, 220 V DC	R&S®IN4150
Power Supply, 115 V AC, 1 phase + N or 230 V AC, 1 or 3 phases + N/208 V AC, 3-phase Δ	R&S®IN4190
Power Supply, 440 V AC, 3 phases (used together with an R&S®BV4190 transformer)	R&S®IN4190
Transformer, 440 V AC, 3-phase Δ	R&S®BV4190
Auxiliary equipment	
Remote control units	
Remote Control Unit	R&S®GB4000C
Remote audio operation	
Audio Unit for R&S®M3SR Series4100 and R&S®M3SR Series4400	R&S®GB4000V
External Power Supply, 24 V/45 W	R&S®NGRA24-GB
Audio units	
Headset, incl. microphone (ruggedized version) with cable and NF-7 connector	R&S®GA012
Handset, incl. microphone (ruggedized version) with cable and NF-7 connector	R&S®GA013
Headset, dynamic with cable and NF-7 connector, with active guard	R&S®GA015
Headset, dynamic with cable and NF-7 connector, without active guard	R&S®GA015A
Handheld Microphone, with cable and NF-7 connector	R&S®GA016H1
Support equipment	
Fill Device	R&S®GP4100A
USB Cable, between fill device and PC	R&S®GK3021

Designation	Type
HF antenna tuning units and postselectors	
HF antenna tuning units (150 W transceiver)	
HF Antenna Tuning Unit, for land-based and shipborne applications	R&S®FK4115M
HF Dipole Antenna, for land-based applications	R&S®HX002H1
HF Dipole Antenna, for shipborne applications	R&S®HX002H2
HF antenna tuning units (500 W/1000 W transceiver systems)	
HF Antenna Tuning Unit, for land-based and shipborne applications, 10.5 m to 12 m rod antennas (model .02)	R&S®FK2900M
HF Antenna Tuning Unit, for land-based and shipborne applications, 30 m to 50 m mast antennas (model .05)	R&S®FK2900M
HF Antenna Tuning Unit, for land-based and shipborne applications, frequency hopping capability	R&S®FK4190M
HF Antenna Tuning Unit, for submarine applications, frequency hopping capability	R&S®FK4150U
1000 W HF Postselection	R&S®FK4190X
R&S®RNMS3000 radio network management system	
Mission Planner	R&S®DS3100M
Remote Device Loader	R&S®DS3300D
Remote Distributor	R&S®DS3321D
Radio test equipment	
Test System for Radio Equipment	R&S®UCS226x

The radio systems described are hardware- and software-configurable. The system delivered has the configuration as confirmed in the order.

Your local Rohde&Schwarz expert will help you determine the optimum solution for your requirements. To find your nearest Rohde&Schwarz representative, visit www.sales.rohde-schwarz.com

Service that adds value

- ▮ Worldwide
- ▮ Local and personalized
- ▮ Customized and flexible
- ▮ Uncompromising quality
- ▮ Long-term dependability

About Rohde & Schwarz

Rohde & Schwarz is an independent group of companies specializing in electronics. It is a leading supplier of solutions in the fields of test and measurement, broadcasting, radiomonitoring and radiolocation, as well as secure communications. Established more than 75 years ago, Rohde & Schwarz has a global presence and a dedicated service network in over 70 countries. Company headquarters are in Munich, Germany.

Environmental commitment

- ▮ Energy-efficient products
- ▮ Continuous improvement in environmental sustainability
- ▮ ISO 14001-certified environmental management system

Certified Quality System
ISO 9001

Certified Quality System
AQAP-2110

Rohde & Schwarz GmbH & Co. KG

www.rohde-schwarz.com

Regional contact

- ▮ Europe, Africa, Middle East | +49 89 4129 12345
customersupport@rohde-schwarz.com
- ▮ North America | 1 888 TEST RSA (1 888 837 87 72)
customer.support@rsa.rohde-schwarz.com
- ▮ Latin America | +1 410 910 79 88
customersupport.la@rohde-schwarz.com
- ▮ Asia/Pacific | +65 65 13 04 88
customersupport.asia@rohde-schwarz.com
- ▮ China | +86 800 810 8228/+86 400 650 5896
customersupport.china@rohde-schwarz.com

R&S® is a registered trademark of Rohde & Schwarz GmbH & Co. KG

Trade names are trademarks of the owners

PD 5213.9557.12 | Version 04.00 | November 2013 (ch)

R&S®M3SR Series4100 Software Defined Radios

Data without tolerance limits is not binding | Subject to change

© 2001 - 2013 Rohde & Schwarz GmbH & Co. KG | 81671 München, Germany



5213955712